

CT cable extension guide

NOTICE

This document does not override any local electrical safety standards, regulations and wiring rules. It is the responsibility of the installer to ensure the shared solar installation meets the relevant regulations and standards in the installation locality.

1. SolShare CTs

TIP

Section 8 of the [SolShare 2 Installation Manual](#) provides information about installing SolShare CTs.

- Each SolShare is supplied with 15 clip-on split-core current transformers (CTs) with locking pin.
- Each CT is supplied with 10m of CT cable attached.
- One CT must be installed for each phase of each tenancy connected to SolShare.

Extending CT cables is required where cable run length between SolShare and the switchboard is more than 10m.

2. Extending CT cables

1 Extend CT cables using the following cables and connectors:

Equipment	SolShare considerations
CT extension cables	<ul style="list-style-type: none"> - Type: Shielded, twisted pair (e.g., shielded CAT6 or instrumentation cable recommended) - Min gauge: 0.25mm² - Max gauge: 2.5mm² - Max length: 100m per CT (including cable provided with CT)
CT extension grounding cable	<ul style="list-style-type: none"> - Min gauge: 0.25mm² - Max gauge: 2.5mm²
CT extension and CT extension shielding connectors	<ul style="list-style-type: none"> - Type: Splicing connector or pluggable terminal block - Recommended type: Wago 221

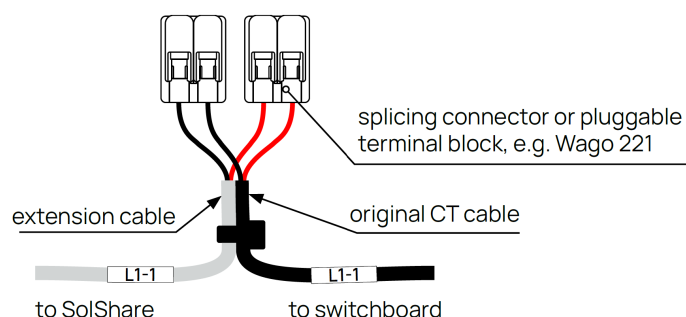

NOTICE

- Failure to use the specified cables and connectors may lead to incorrect CT readings, which may potentially slow down or prevent successful SolShare commissioning and operation.
- Ensure there is good electrical contact between original and extended CT cables.
- Ensure shielding is not compromised along the entire length of original and extended CT cables. Avoid the use of materials that could compromise shielding, such as metal cable ties.
- Label each end of the original and extended CT cables with the SolShare tenancy connection (e.g., L1-1). This will assist with efficient installation and troubleshooting.

2 Earth the shielding of any extended CT cables in SolShare.

NOTICE

Avoid overloading the SolShare's CT earthing terminals with too many cables. Use splicing connectors (e.g. Wago 221) to group CT extension shielding together. Use insulated cable from splicing connector/s to SolShare's CT earth terminals. Keep the length of exposed shielding to a minimum.

