



Consumer Unit Connection SLD

Example- GUIDANCE ONLY

Note:

This design **DOES NOT SUPPORT BATTERY** integrations. Contact Allume when designing any battery project.

GUIDANCE NOTE: Installation must fully conform to BS7671 Wiring Regulations

Typical install location:

Energy Meter in Flat

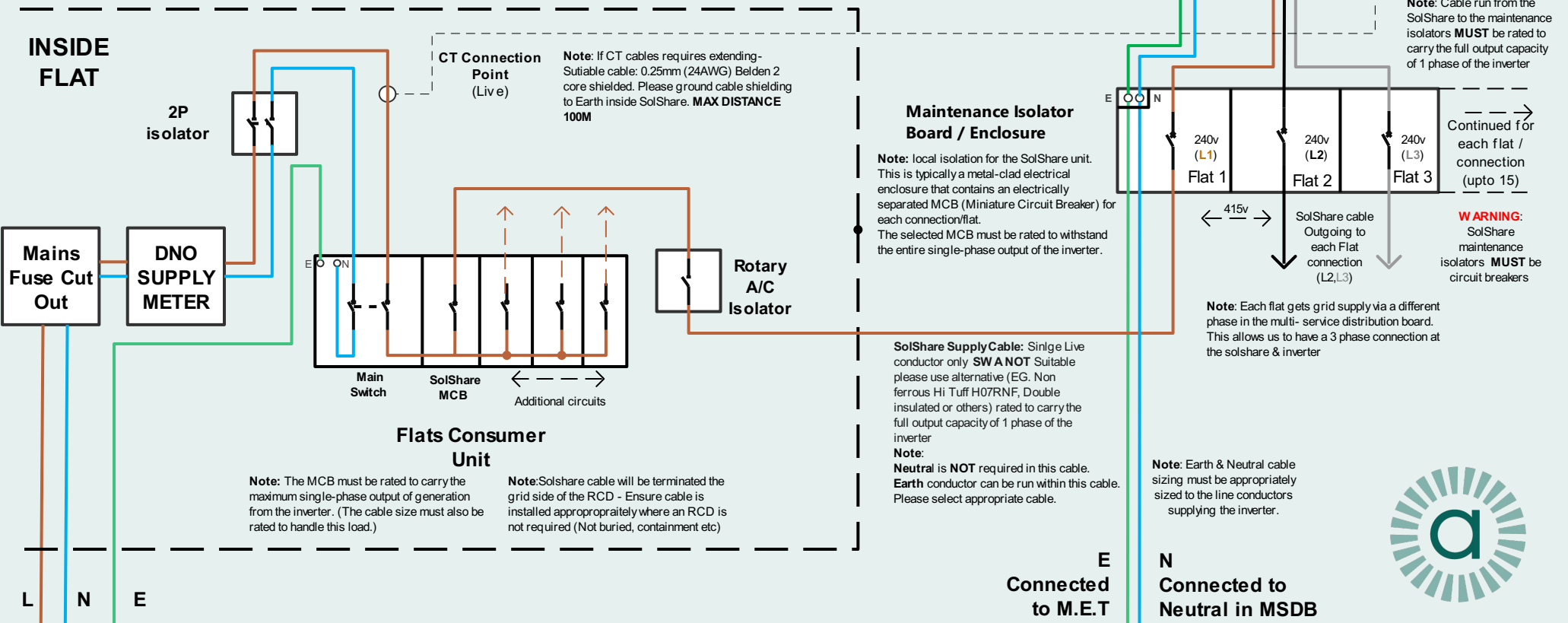
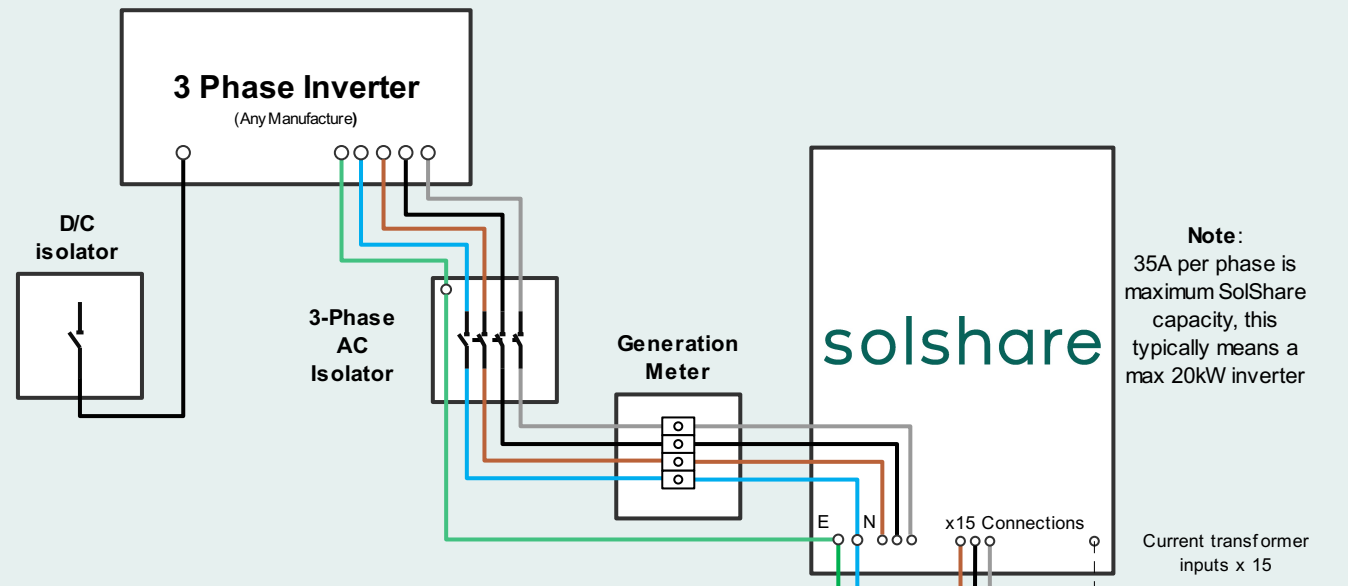

Multi-Service Distribution Board (MSDB)

