

# SolShare isolation box

## Installation guide

SolShare installations in Australia require an isolation box between the SolShare outputs and the Tenancy Main Switches (Inverter Supply). Allume offers an additional SolShare Isolation Kit that provides many of the required components for the isolation box.

This document serves as a guide only to help installers understand the standard installation procedure for the isolation box. The actual installation process may vary depending on the existing electrical infrastructure and local electrical safety standards.

- It is the responsibility of the electrician to ensure their installation meets local electrical safety standards.
- Always follow local electrical codes and standards for solar installations.
- Use appropriate personal protective equipment (PPE) when performing electrical work.

### **! WARNING**

Adhere to all handling and safety instructions during installation, testing, and inspection. Failure to do so may result in injury, loss of life, or damage to equipment.

## I/ Equipment Required

Equipment	Quantity per SolShare	Included in SolShare Isolation Kit?
40A NO (normally open) contactors	1 per SolShare output phase connection in use	Yes – 15 included
1A single phase MCB (miniature circuit breakers)	1 per single phase SolShare output connection in use	Yes – 15 included
1A three phase MCB (miniature circuit breakers)	1 per three-phase SolShare output connection in use	No
9mm DIN-rail spacers (optional, based on installation requirements)	1 per SolShare output phase connection in use	Included in selected kits
Neutral cables	As required	No
Cables for connections between contactors and MCBs	As required	No
Necessary tools for wiring (screwdrivers, wire strippers, torque screwdriver, bootlaces, etc).	As required	No
Suitable enclosure (configurable as required per total number of connections).	1	No
<b>It is the responsibility of the installer to source an appropriately-sized enclosure to fit the isolation components.</b>		

## II/ Installation Steps

### A. Preparation

1. Ensure the system is de-energised before beginning the installation.
2. Verify that all necessary tools and components are available.
3. Ensure you have the correct number of contactors and MCBs required for the job.

**Note:** Each output connection from the SolShare must be connected to its own contactor.

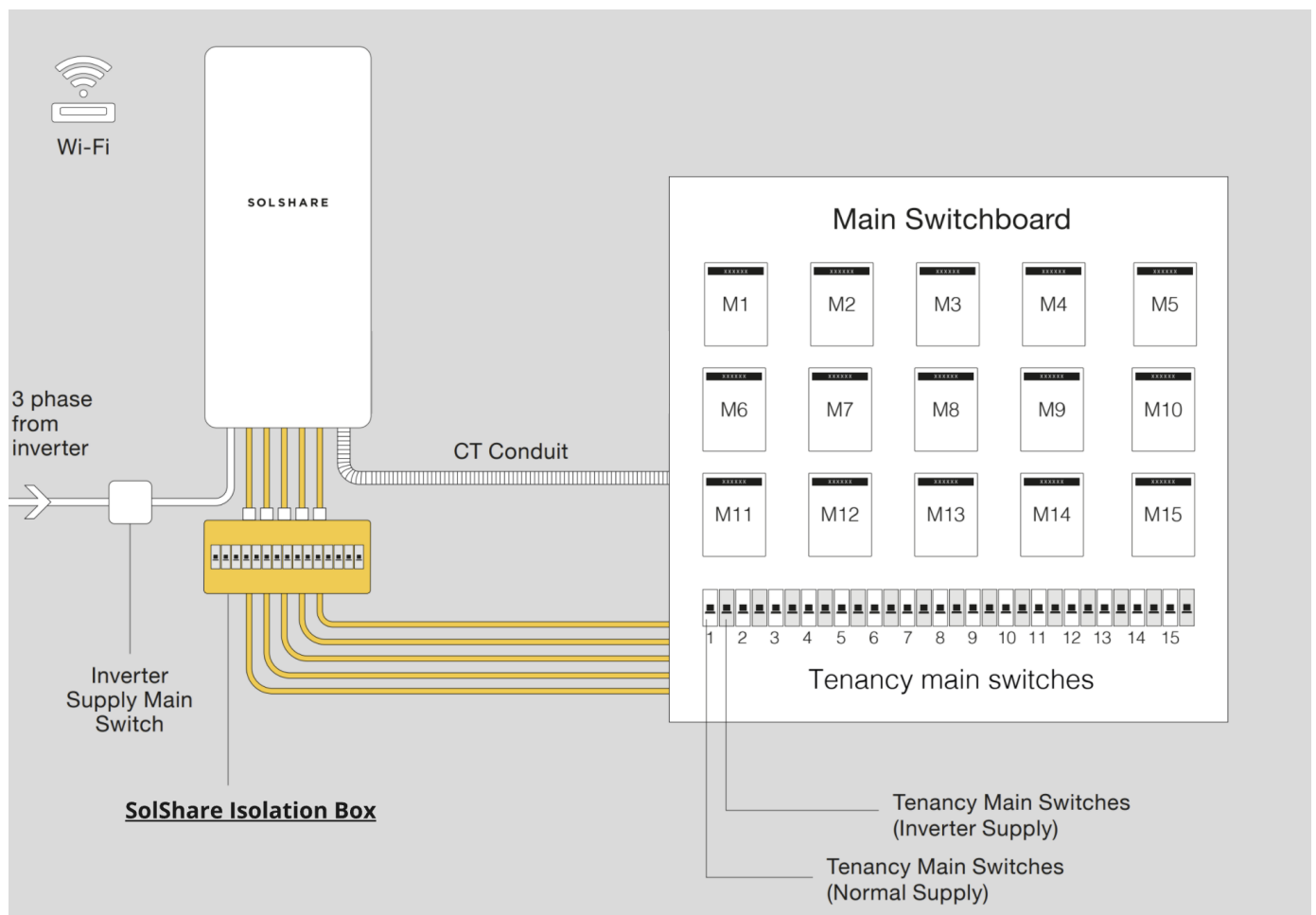

Figure 1: SolShare installation setup

### B. Mounting the Isolation Box

1. Secure the SolShare isolation box near the SolShare outputs in a location that is both accessible for maintenance and safe from environmental factors such as direct sunlight and rain.
2. Maintain appropriate clearances for the isolation box for ease of maintenance.

## C. Wiring the 240V AC 40A NO Contactors and 1A MCB for control coil

### 📌 IMPORTANT

The SolShare Isolation Kit provides 15 x 1A single phase MCBs. If three phase MCBs are required, these must be sourced by the installer.

1. Install the 240V AC 40A NO contactors on the din rail within the enclosure. The enclosure should be selected based on the total number of contactors to be utilised.
  - The isolation equipment (240V AC 40A NO Contactors) shall be installed with a 1A MCB beside each to act as protection for the coils and as a means of isolating the SolShare output connection.
  - Refer to Figure 2 below for more information.

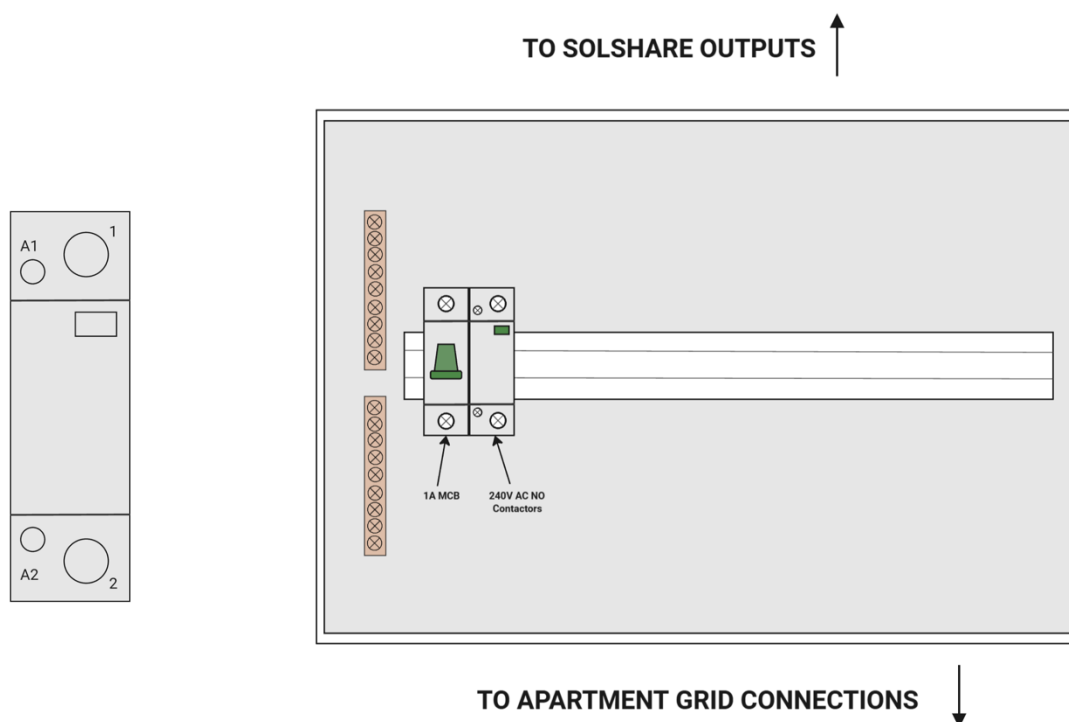

Figure 2. Contactor and MCB arrangement

2. Connect the contactor's control coil terminal, labelled "A1", to the contactor's grid input terminal, labelled "2," by utilising the 1A MCB provided as part of the SolShare Isolation Kit, as shown in Figure 3.
3. Connect the coil's (A2) neutral connection to the neutral bar in the isolation box using appropriately sized cables, as shown in Figure 3. Ensure the neutral bar in the enclosure is linked back to the main neutral bar at the main switchboard (MSB) that has the Multiple Earthed Neutral (MEN) link.

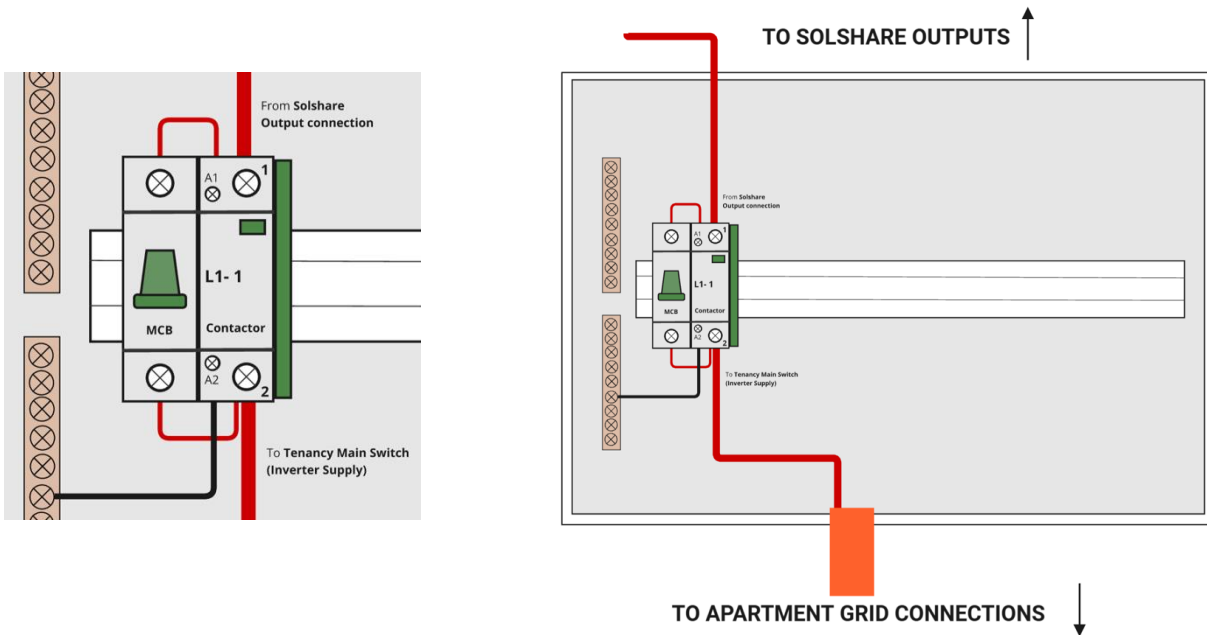

Figure 3. Contactor Coil Wiring

4. The A1 and A2 connections will act as the controls for engaging the contactors, so ensure the cables are terminated correctly into the terminals.
5. Wire the contactors and connect one for each SolShare output, as shown in Figure 4.
6. For demonstration purposes, this document shows an installation with only the isolation equipment for a SolShare with 6 (six) single-phase output connections.
7. If required, install the 9mm Din-rail spacers in between contactors to aid heat dissipation, as shown in Figure 4.

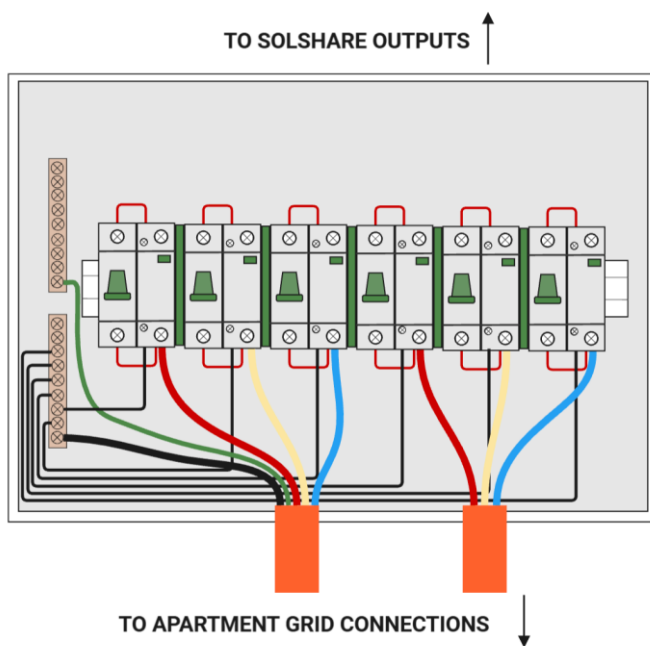

Figure 4. Isolation Box Internal wiring

## D. Connecting SolShare Outputs:

1. For each SolShare output (i.e. L1-1, L2-1, L3-1, ..... L2-5, L3-5), connect the cables to the contactor terminals labelled "1" on the respective contactors as shown in Figure 5.

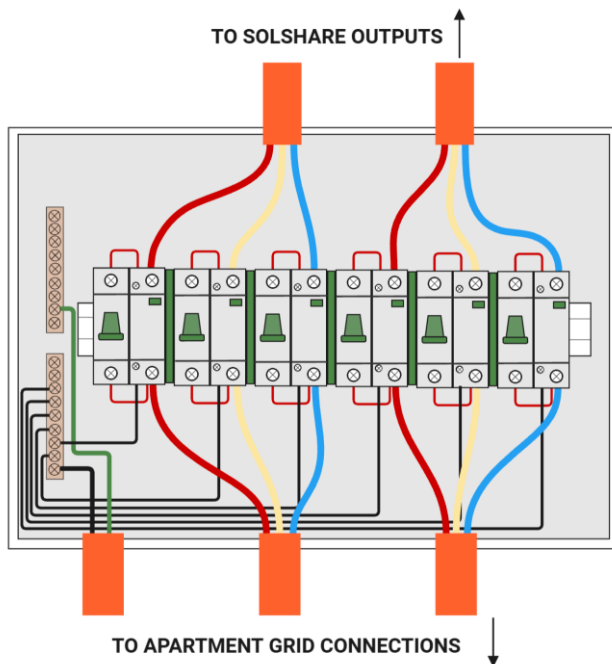

Figure 5. Full Isolation Box Internal wiring

2. After completing the wiring, verify that the polarity and phases are correctly aligned according to the Single-Line Diagram and project system requirements.
3. Once the wiring is completed, turn OFF all MCBs to isolate SolShare and label the contactor/MCB for ease of identification.

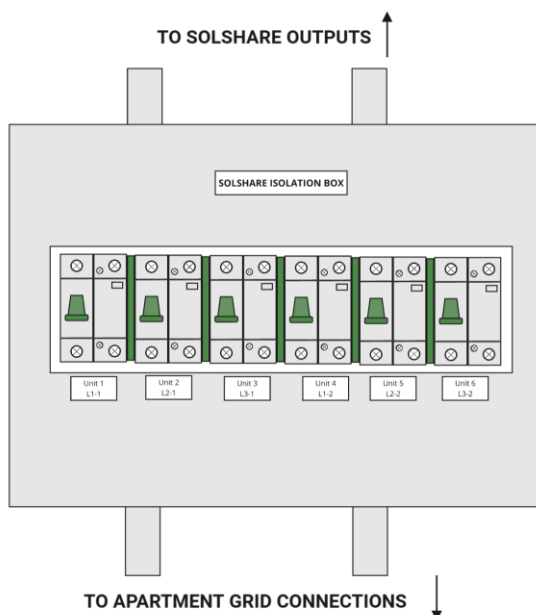

Figure 6. Isolation Box

## E. Testing the Installation

- Once all connections are made, conduct a thorough check to ensure all wires are securely connected and properly insulated to prevent any potential electrical hazards.
- Carry out a phase-to-phase (as shown in Figure 7) and phase-to-neutral check on all connections to ensure the wiring has been completed in the right sequence.

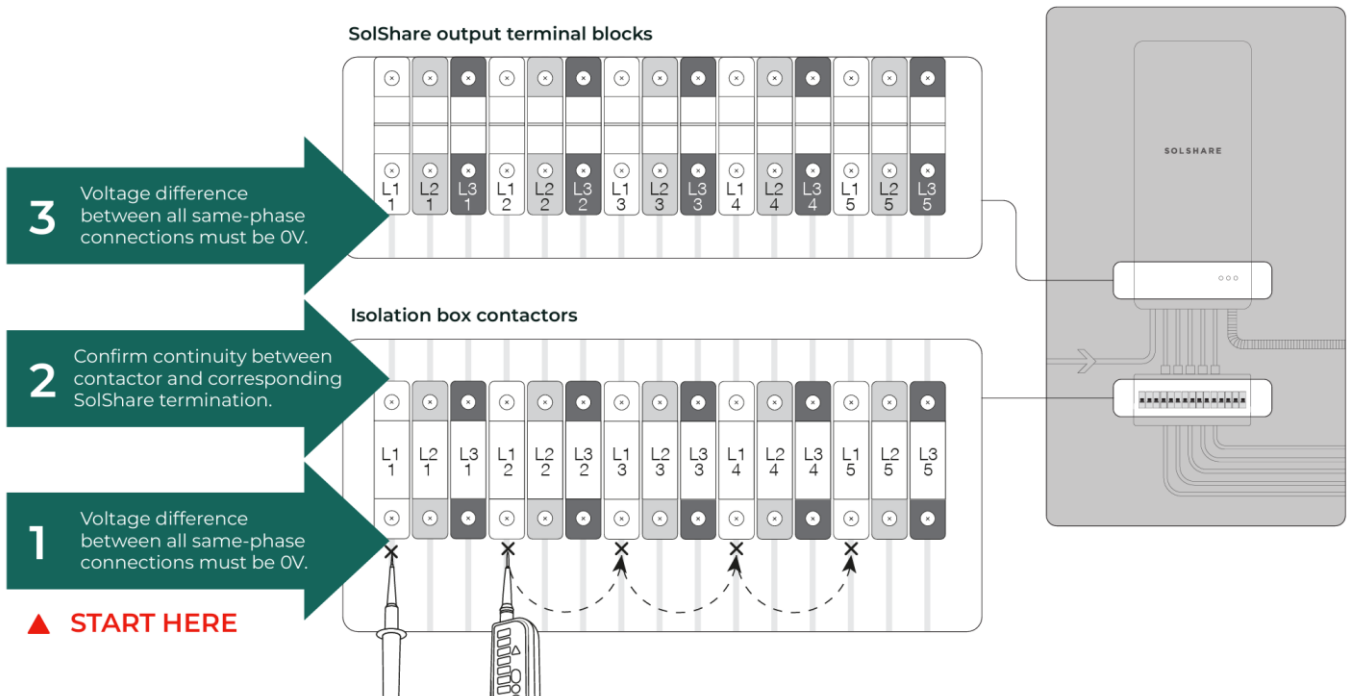

Figure 7. Phase-to-phase Checks

- Temporarily power the system to test the functionality of each contactor and the integrity of the entire isolation box setup. The indicator on the contactors should turn red once energised.

## F. Final Setup and Commissioning

- After the installation setup has been verified, turn off the system to finalise any remaining setup.
- Secure all covers and protection on the isolation box.
- Continue with SolShare commissioning. Refer to the *SolShare Installation Manual* available in the [Resource Library](#) for instructions on how to commission SolShare.